

PIONEER ARC[®]

鐸 & 切 自 動 化 設 備 製 造 CE
Manufacturer Of Auto Welding And Cutting Equipment

聯懷企業有限公司
LEHAI ENTERPRISE CO., LTD.
聯寶機電有限公司
LEPAO ELECTRICITY MACHINERY CO., LTD.

413 台中市霧峰區民生路198巷26弄19號
No.19, Aly.26, Ln.198, Minsheng Rd., Wufeng Dist.,
Taichung City 413, Taiwan

TEL: 886-4-2333-2019 FAX: 886-4-2339-0627
Email: Lh2137@ms27.hinet.net
<http://www.Lehai.com.tw>; www.pioneerarc.com.tw



關於我們 ABOUT US

聯懷企業/聯寶機電(PIONEER ARC)專業製造銲接&切割自動化設備，銲接轉盤及銲接十字架..等。將近30年來不斷致力於研究發展，強化專業技能，提昇效率品質。本公司堅持追求完美、精益求精、努力開發及改良銲接自動化設備及切割自動化設備。主動積極了解客戶需求，提供完善售後服務。不斷增進國際視野，提昇效率品質，以最優質的產品來滿足客戶需求。

Pioneer Arc specializes in designing and manufacturing advanced welding and cutting automation equipment, including welding positioners, manipulators, and more.

With nearly 30 years of experience, we focus on continuous innovation, enhancing professional skills, and improving product quality.

Our commitment lies in perfecting welding and cutting technologies to deliver reliable, high-performance solutions that meet the needs of our customers.

By actively understanding customer requirements, we ensure exceptional after-sales service. Through a global perspective and constant pursuit of excellence, we strive to provide the best welding and cutting solutions for every application.



電控室 Electronic Control Department



工廠實景 Factory



設計部門 Design Department

- ◆ 轉盤承載：200KG~20,000KG (可選擇)。
- ◆ 採蝸桿 / 蝸輪傳動，低背隙，自鎖性，低震動。
- ◆ Positioner load capacity : 200KG~20,000KG (optional).
- ◆ Worm gear transmission, low backlash, Self-locking, low vibration

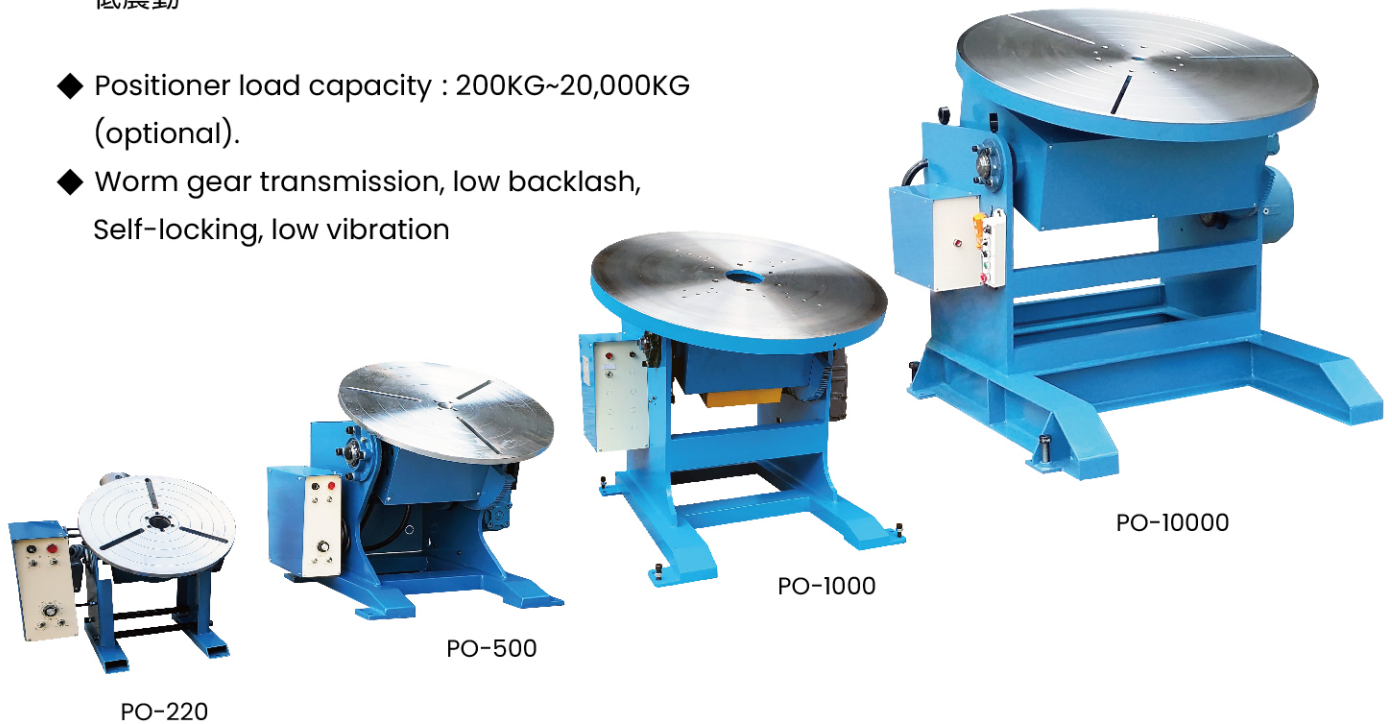

自組式自動轉盤設備 Easy Assembling Automatic Positioner



- ◆ 採鋸槍迴轉或轉盤迴轉。
- ◆ 自動送料系統(選擇性配備)。
- ◆ 數位式控制系統，可手動 / 全自動控制，操作容易。
- ◆ 可多點定位設計。
- ◆ Supports torch or table rotation for flexible welding.
- ◆ Optional auto-feeding system for higher efficiency.
- ◆ Digital controls with manual and automatic modes, easy to operate.
- ◆ Multi-point positioning for precise results.



鋸槍迴轉 Torch Rotation

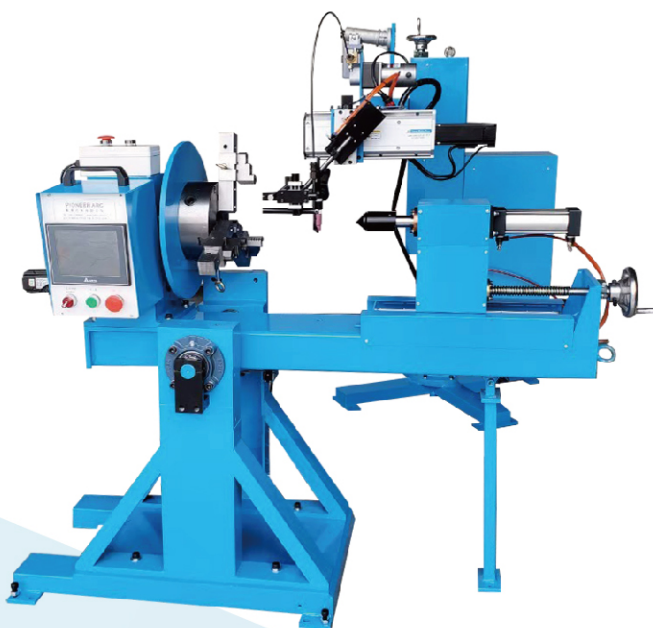

立/臥式二用銲接機 Vertical / Horizontal Positioner



桌上型立式迴轉 Desktop Type Positioner



立式轉盤迴轉 Table Rotation

- ◆ 可依工件直徑、長度、材質不同，選擇設計。
- ◆ 自動送料系統精準、功能佳。
- ◆ 可適用於TIG/PLASMA/CO2銲接設備。
- ◆ 採數位控制系統，可手動/全自動控制，操作容易。
- ◆ Supports various workpiece diameters, lengths, and materials, with customizable designs.
- ◆ High-precision automatic feeding system for smooth operation.
- ◆ Compatible with TIG, PLASMA, and CO2 welding systems.
- ◆ Easy-to-use control system with manual and automatic operation modes.



臥式-伺服控制 Horizontal - Servo Control



臥式-人機介面控制 Horizontal - Hmi Control

- 適桶槽，長度1250mm，直徑1000mm
- Applicable for tanks, length 1250mm, diameter 1000mm

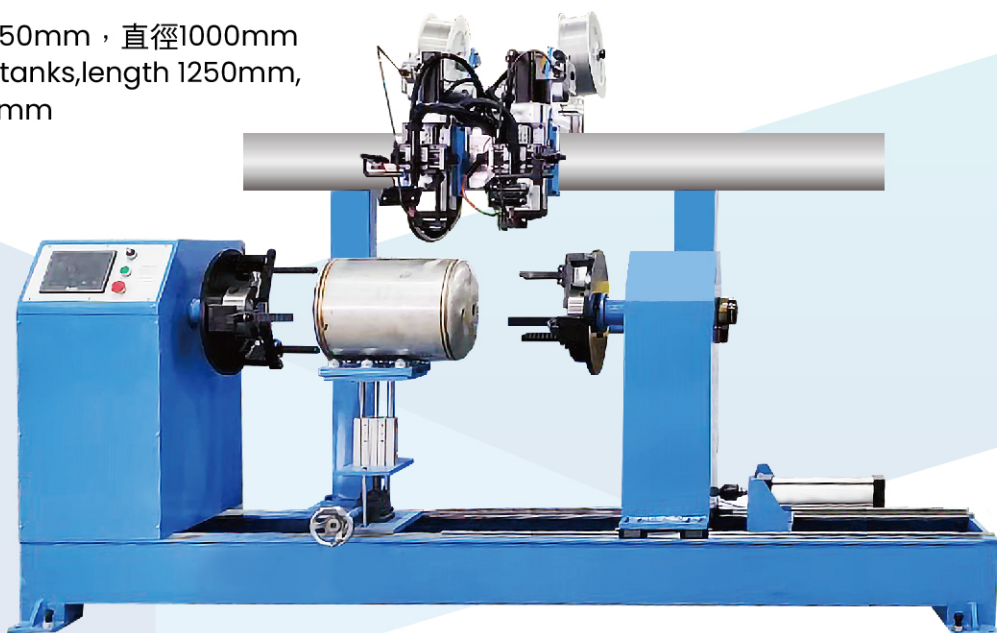

臥式雙槍銲接設備(送線添料系統)
Horizontal Dual-Gun Welding Equipment (Wire Feeder)

雙軸滾圓機(標準型) Bending Rolls (Standard Model)

- ◆ 優力膠滾輪，耐磨耗、壽命長,不傷工件表面。
- ◆ 可依直徑、長度(最長2000mm)訂製。
- ◆ 可選直筒型或錐型。
- ◆ 雙軸滾圓機(標準型)，厚度最大：2.0mm。
- ◆ Polyurethane rollers are wear-resistant, durable, and gentle on workpiece surfaces.
- ◆ Customizable to specific diameters and lengths (up to 2000mm).
- ◆ Available in cylindrical or tapered designs.
- ◆ Dual-axis bending rolls (standard model) handle thicknesses up to 2.0mm.



BR-600



BR-1300

雙軸滾圓機(重力型) Bending Rolls (Heavy Model)

- ◆ 雙軸滾圓機(重力型)，厚度最大：4.0mm。
- ◆ Bending rolls(heavy)
Maximum thicknesses up to 4.0mm.



BRT-1600

三軸滾圓機 3rolls Bending Rolls



TEBR-2500

- ◆ 銲接方式可採氬銲(TIG)，電離氣銲(Plasma)，CO2銲(MIG)，潛伏銲(Submerged)，鐳射銲(Laser Welding)..等。
- ◆ 適用於金屬圓筒、方筒、平板…
- ◆ 適用工件長度：100~6,000mm(最長)。
- ◆ Compatible with TIG, Plasma, CO2, Submerged, and Laser welding machines.
- ◆ Suitable for round tubes, square tubes, and flat sheet metals.
- ◆ Supports workpiece lengths from 100mm to 6,000mm.



SI-1000 電離子銲接 (Plasma Welding)



SI-1600電離子銲接/送線添料系統
(Plasma Welding / Wire Feeder)



Mp-3000 電離子銲接 (Plasma Welding)

- ◆ 可應用氬銲(TIG)，電離氣銲(PLASMA)，CO2銲(MIG)，潛伏銲(Submerged)，可配合自動送料設備。
- ◆ 手動 / 電動垂直軸旋轉。
- ◆ 適用工件直徑×長度：6,000mm×6,000mm。
- ◆ Works with TIG, Plasma, MIG, and Submerged welding systems, and pairs well with automatic feeding equipment.
- ◆ Vertical axis rotation can be manual or electric.
- ◆ Handles workpieces up to 6,000mm in diameter and length.

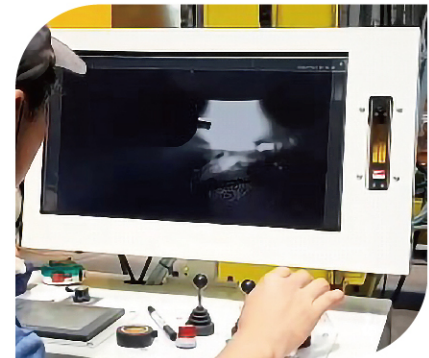

銲接攝影機(Welding Camera)



Mp-5000 電離子銲接 (Plasma Welding)

- ◆ 優力膠輪設計、耐磨、壽命長、不傷工作表面。
- ◆ 螺栓固定或方螺桿調整輪距、確實且容易。
- ◆ 扭力安定、傳動確實、速度反應靈敏。

- ◆ Designed with polyurethane wheels for high wear resistance, long service life, and protection of workpiece surfaces.

- ◆ Bolt fastening or square screw adjustments for precise and easy wheel spacing.

- ◆ Stable torque, reliable transmission, and responsive speed control.



- 插銷式滾輪 : 1T ~ 5T
- Pin Type Roller : 1T ~ 5T

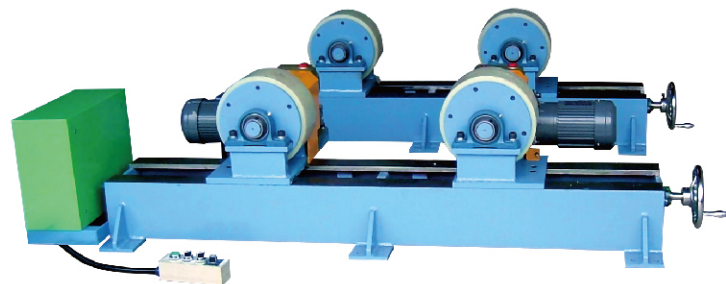

- 可調式滾輪 : 2T ~ 80T
- Adjusting Roller : 2T ~ 80T

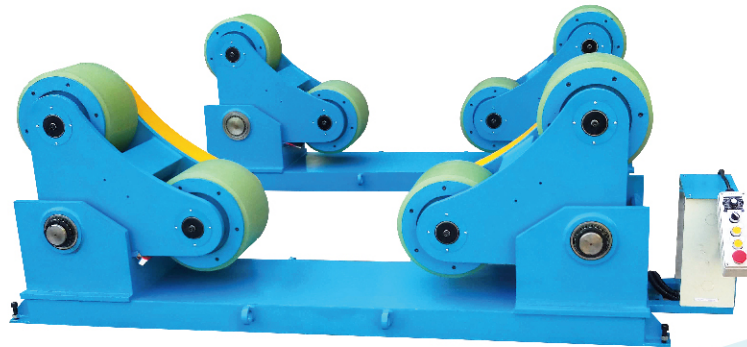

- 自調式滾輪 : 5T ~ 150T
- Self-Adjusting Roller : 5T ~ 150T

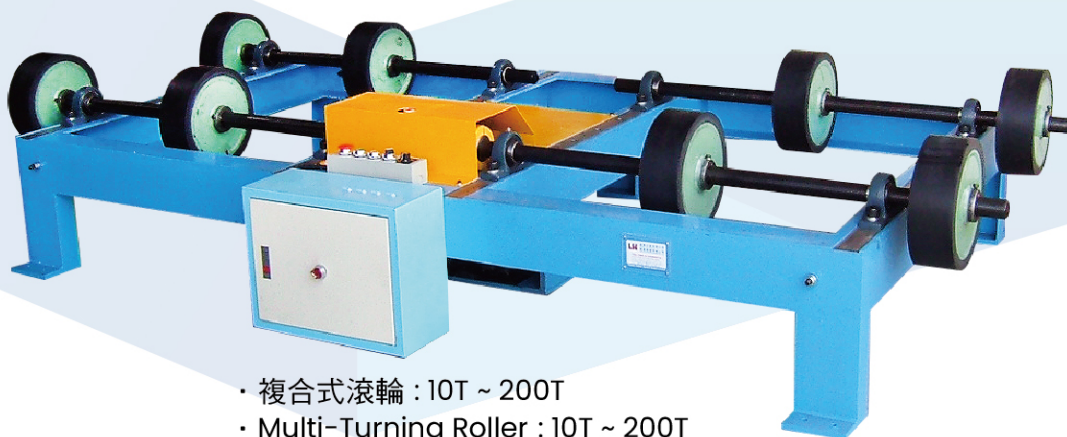

- 複合式滾輪 : 10T ~ 200T
- Multi-Turning Roller : 10T ~ 200T

- ◆ 超強氣/油壓雙刃裁剪，平直省力。
- ◆ 氣/油壓簡易銅模夾持，快速確實。
- ◆ 可適用氬鋸、CO2鋸接..等。
- ◆ High-performance pneumatic/hydraulic double-edged cutting, delivering precision and efficiency.
- ◆ Simple and reliable pneumatic/hydraulic clamping with copper modules.
- ◆ Compatible with TIG and CO2 (MIG) welding systems.



連續沖模業用裁鋸機
Industrial Continuous
Stamping Shear Welder



送料機
Uncoiler

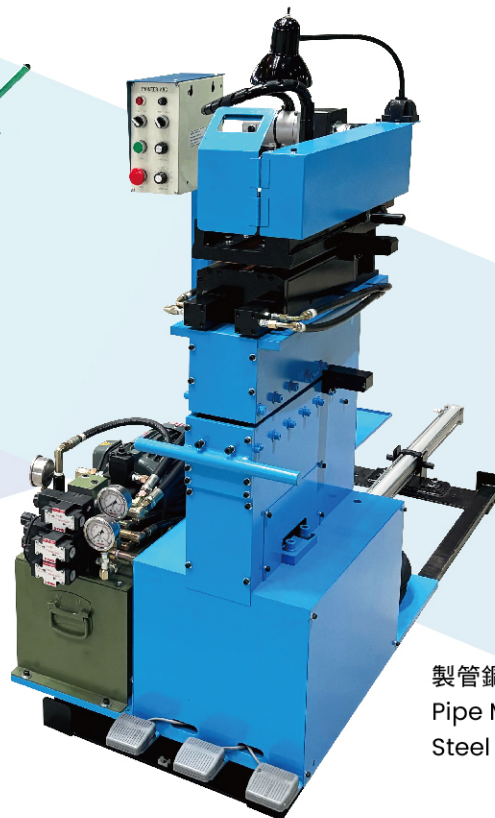

製管鋼帶用裁鋸機
Pipe Manufacturing
Steel Strip Welder

型號 Model	氣壓系列 Pneumatic Series			油壓系列 Oil Hydraulic Series			
	PSW-168	PSW-250	PSW-380	PSWH-168	PSWH-250	PSWH-380	PSWH-420
裁剪, 鋸接板寬 Strip Width	168 mm	250 mm	380 mm	168 mm	250 mm	380 mm	420 mm
裁剪, 鋸接板厚 Strip Thickness	2.0 mm	2.0 mm	2.0 mm	2.5 mm	4.0 mm	4.0 mm	4.0 mm
裁剪/夾持系統 Shearing / Clamping System	氣壓 Pneumatic	氣壓 Pneumatic	氣壓 Pneumatic	油壓/氣壓 Oil Hydraulic / Pneumatic	油壓/油壓 Oil Hydraulic / Oil Hydraulic	油壓/油壓 Oil Hydraulic / Oil Hydraulic	油壓/油壓 Oil Hydraulic / Oil Hydraulic

全自動大型裁鋸機

AUTOMATIC METAL STRIP SHEAR WELDER

PIONEERARC®

型號：ASW系列
Model：ASW Series

- ◆ 適用裁剪厚度：1.2~16mm
- ◆ 裁剪板寬：250~1600mm
- ◆ 金屬板端可手動調正
- ◆ 端間隙可手動調整

- ◆ Strip thickness：1.2~16mm.
- ◆ Strip width：250~1600mm.
- ◆ Manual correction for metal strips.
- ◆ Manual adjustment of strip gaps.

全自動大型裁鋸機
Automatic Metal
Strip Shear Welder



整平機
Straightener



送料機
Uncoiler



送料機
Uncoiler

整平機
Straightener



全自動大型裁鋸機
Automatic Metal Strip Shear Welder

- ◆ 伺服傳動系統,無間隙。
- ◆ NC多元操作設定方便。
- ◆ 適精密銲接,旋轉精準。
- ◆ Servo-driven system for precise and gapless positioning.
- ◆ NC system enables easy pre-sets and versatile operations.
- ◆ Delivers accurate rotation, ideal for precision welding tasks.



翻轉定位台
Tilting Positioning Table

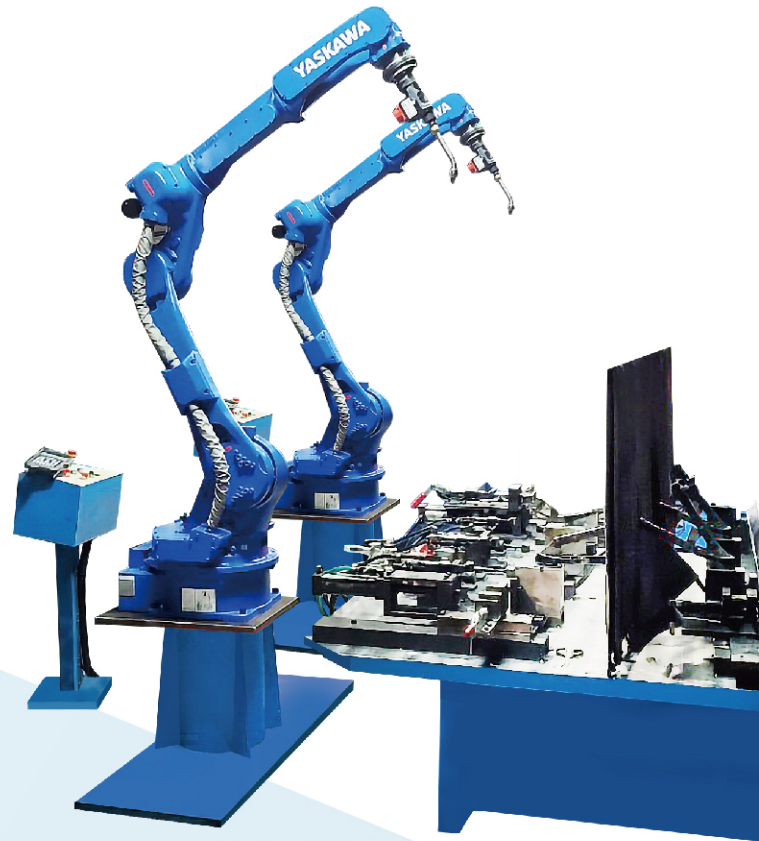

轉盤迴轉定位台
Rotational Positioning Table



臥式移行定位台
Horizontal Moving Positioning Table

鐳射切割

AUTOMATIC LASER CUTTING MACHINE

PIONEERARC®

- ◆ PC控制器，中文化畫面，操作簡易。
- ◆ 穩定性高，切割確實。
- ◆ 圖檔上傳容易，排版可即時預覽調整。
- ◆ PC-based controller with an intuitive and user-friendly interface.
- ◆ Ensures high stability and precise cutting performance.
- ◆ Easy file upload with real-time layout preview and adjustments.

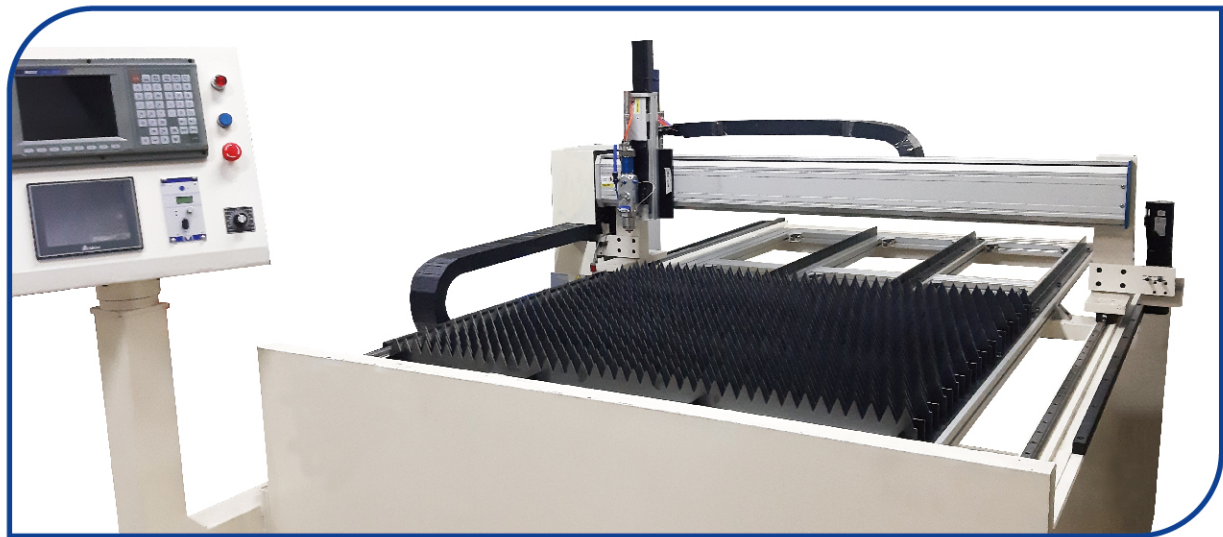

鐳射自動直線銲接機 Automatic Laser Seam Welder





螢幕顯示狀態
Screen Display Status

特點：

- ◆ 鐳接溫升變形、氧化影響小。
- ◆ 超精密鐳接可縮短鐳後加工成本。

應用：

- ◆ 模具修補 ◆ 精密鐳接
- ◆ 汽機車、紡織、機械零件、產業機械零件、
光纖電纜、醫療用工業航太工業..等。

Features:

- ◆ Minimal deformation and oxidation during welding.
- ◆ Ultra-precision welding reduces post-weld processing costs.

Application:

- ◆ Mold repair and precision welding.
- ◆ Automobiles, motorcycles, textiles, machinery parts, industrial equipment, optical fiber cables, medical devices, and aerospace industries...

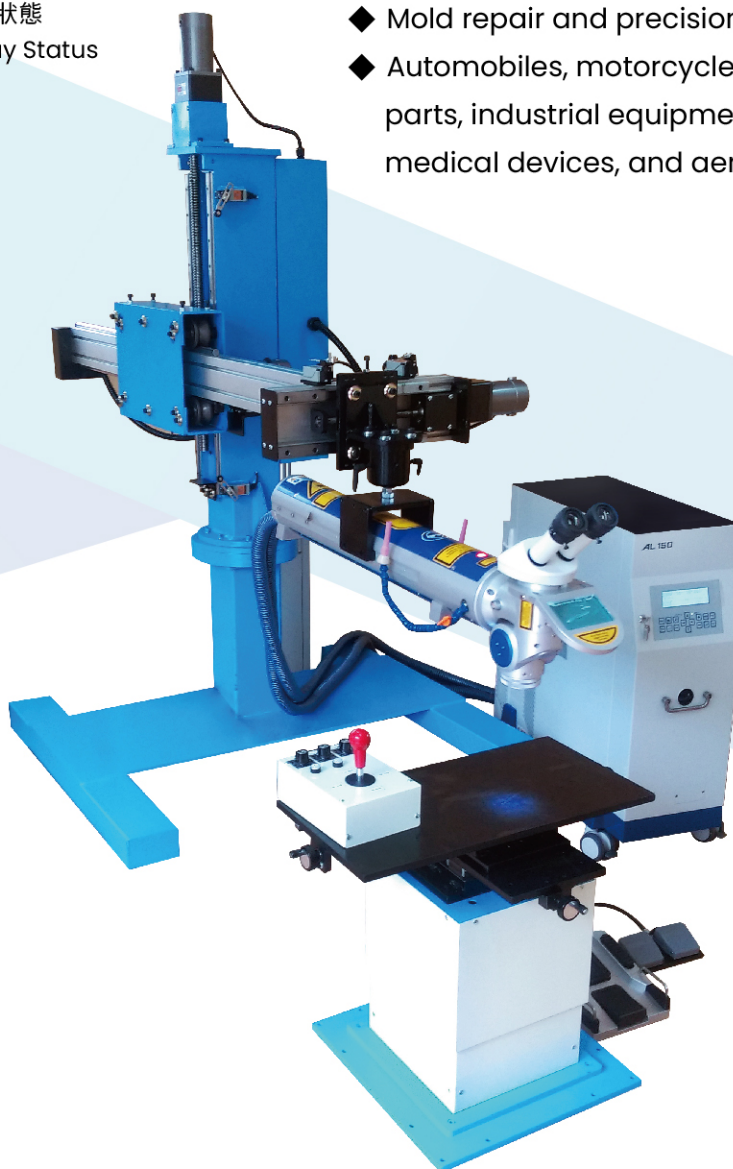

整廠專用設備及專利製品

WHOLE FACTORY CUSTOMIZED MACHINE AND PATENTED PRODUCTS

PIONEERARC®

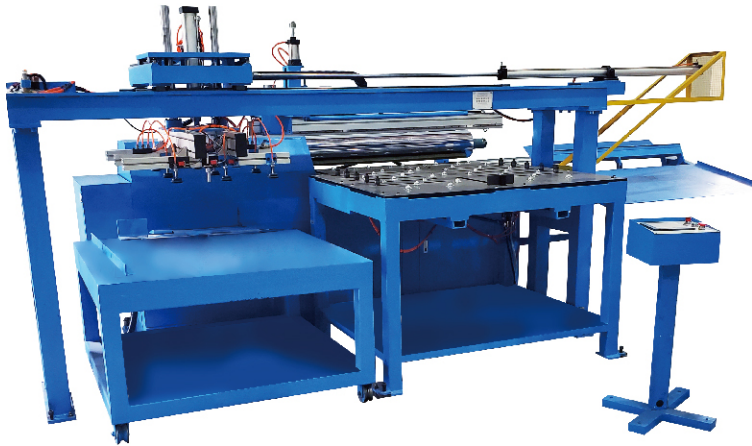

全自動雙軸滾圓機
Automatic Bending Rolls(Two Rolls)



金屬銲/切煙霧集塵機
Metal Welding &
Cutting Fume Collector

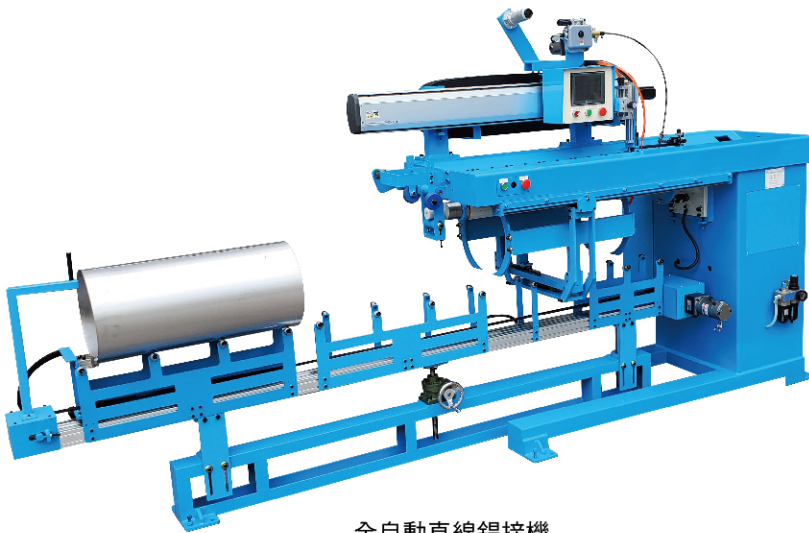

全自動直線銲接機
Automatic Seam Welder

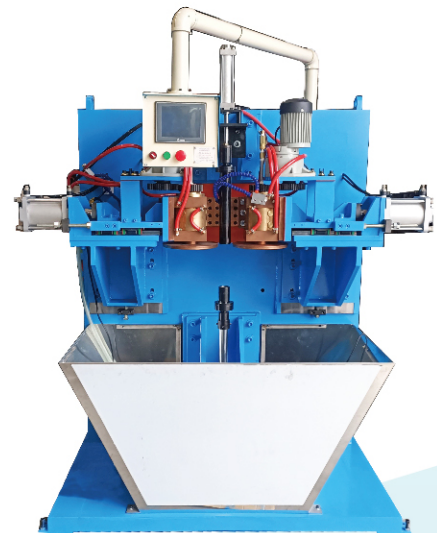

自動雙輪銲機
Automatic Twin-Wheel
Welding Machine



銲接攝影機
(Welding Camera)

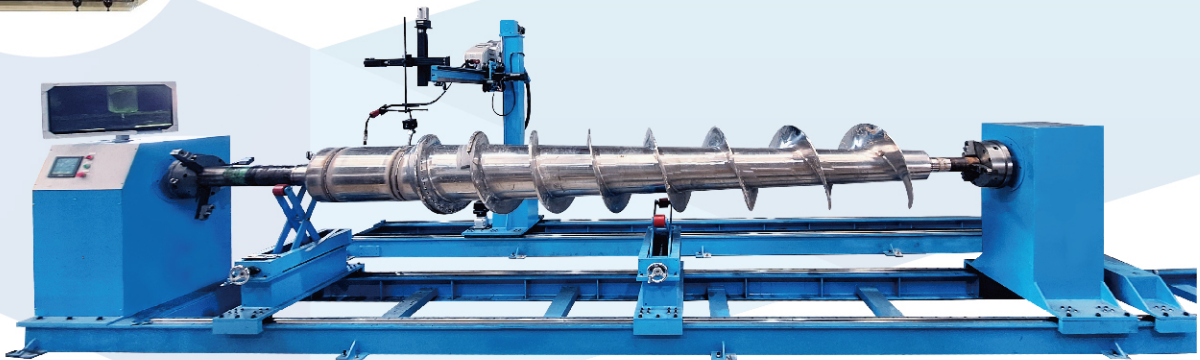

螺旋桿臥式自動銲接機
Horizontal Screw Rod Automatic Welding Machine

PIONEER ARC[®]



2025.01

鐸 & 切 專用 自动化 設備 製造 / 設計
Manufacturing/Design Of Specialized Welding & Cutting Automation Equipment